

# CANTILEVER DETAILS

## RFPI®-JOIST CANTILEVER DETAIL FOR BALCONIES

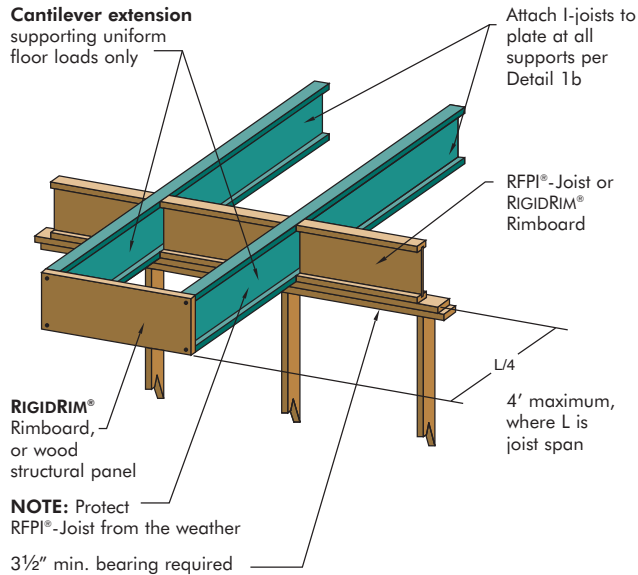

**CAUTION:** Cantilevers formed this way must be carefully detailed to prevent moisture intrusion into the structure and potential decay of untreated I-Joist extensions.

## LUMBER CANTILEVER DETAIL FOR BALCONIES

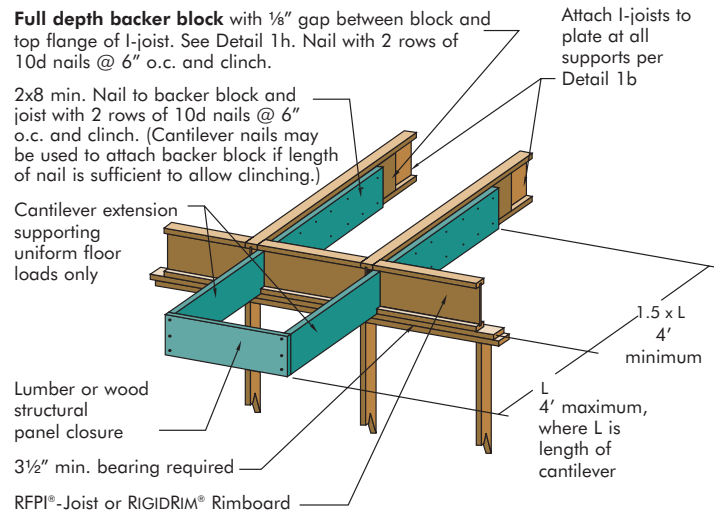

## CANTILEVER DETAIL FOR VERTICAL BUILDING OFFSET

### METHOD 1

SHEATHING REINFORCEMENT ONE SIDE

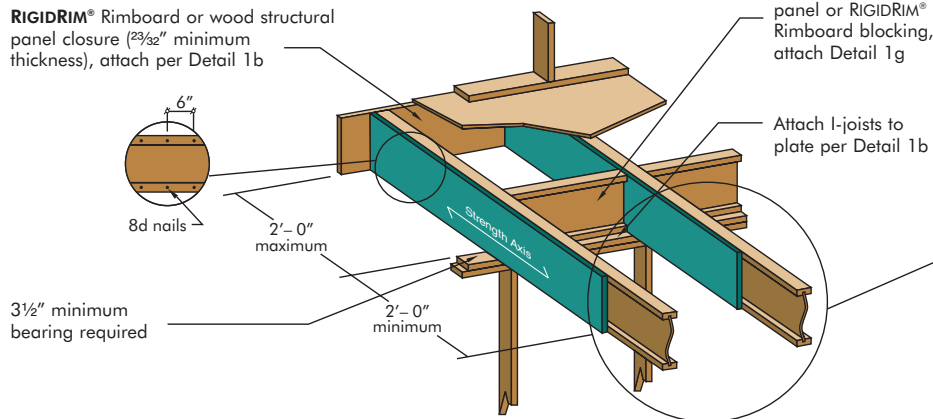

**Note:** APA RATED SHEATHING 48/24 (minimum thickness 2 3/32") required on sides of joist. Depth shall match the full height of the joist. Nail with 8d nails at 6" o.c., top and bottom flange. Install with face grain horizontal. Attach I-joist to plate at all supports per Detail 1b.

### METHOD 2

SHEATHING REINFORCEMENT TWO SIDES

Use same installation as Method 1 but reinforce both sides of I-joist with sheathing

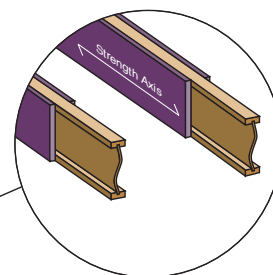

Use nailing pattern shown for Method 1 with opposite face nailing offset by 3"

CANTILEVER DETAIL FOR VERTICAL BUILDING OFFSET

**ALTERNATIVE METHOD 2**  
DOUBLE RFPI®-JOIST

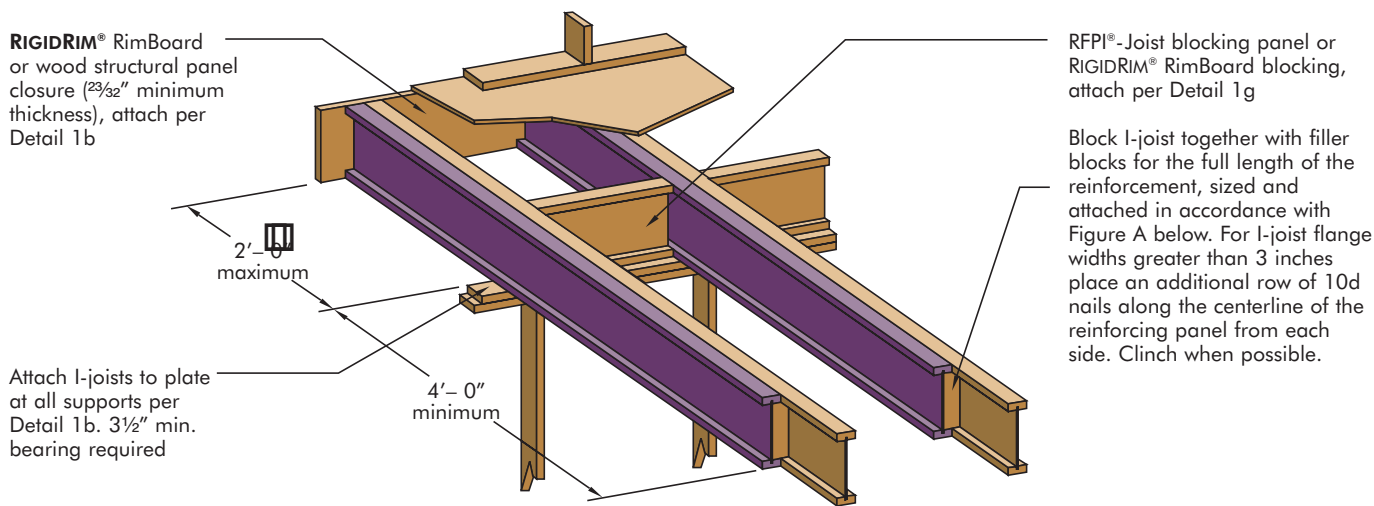
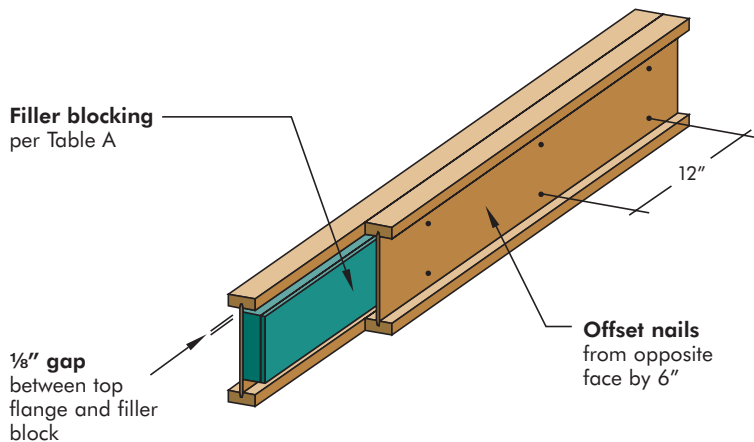

FIGURE A

**DOUBLE RFPI®-JOIST CONSTRUCTION**



**Notes:**

1. Support back of I-joist web during nailing to prevent damage to web/flange connection.
2. Leave a 1/8" gap between top of filler block and bottom of top I-joist flange.
3. Filler block is required between joists for full length of span.
4. Nail joists together with two rows of 10d nails at 12" o.c. (clinched when possible) on each side of the double I-joist. Total of 4 nails per foot required. If nails can be clinched, only 2 nails per foot are required.

TABLE A

**FILLER BLOCK REQUIREMENTS FOR DOUBLE RFPI®-JOIST CONSTRUCTION**

Flange Width	Depth	Filler Block Size
1 1/2"	9 1/2"	1 1/8" x 6" high
	11 7/8"	1 1/8" x 8" high
1 3/4"	9 1/2"	1 3/8" x 6" high
	11 7/8"	1 3/8" x 8" high
	14"	1 3/8" x 10" high
	16"	1 3/8" x 12" high
2 5/8"	9 1/2"	2" x 6" high
	11 7/8"	2" x 8" high
	14"	2" x 10" high
3 1/2"	16"	2" x 12" high
	11 7/8"	3" x 8" high
	14"	3" x 10" high
	16"	3" x 12" high